

Transportation Alternatives Program 2023 Application

Instructions

Complete application in the space provided. Applicants are limited to application form and 5 pages of attachments. Submit completed application and attachments electronically to dale.robins@rtc.wa.gov. You will receive an e-mail confirmation within one business day of submittal. If you do not receive confirmation or have questions about the application contact Dale Robins at 564-397-5212.

General Information

Project Title: Garrison Road Sidewalk Infill

Project Location and Limits: Mill Plain Blvd to NE 12th St

Project Length (miles): 0.4 mile

Agency: City of Vancouver

Contact Person: Emily Benoit

Telephone: 360-487-7944 Email: Emily.Benoit@CityofVancouver.us

Certified Acceptance Agency: City of Vancouver

Project Screening Criteria

Check all that apply.

- Project is consistent with the RTP
- Project contains at least one eligible Transportation Alternatives Category
- Project is directly related to the surface transportation system (except trails)
- Project does not supplement the construction of an existing project
- Project is open to public access

Cost Summary

Project Phase	Start Date	TAP Funds	Other Funds	Total Cost
Design	09/01/2023	0	\$165,000	\$165,000
Right of Way	09/01/2024	0	\$317,000	\$317,000
Construction	05/01/2026	\$350,000	\$550,000	\$900,000
Totals	n/a	\$350,000	\$1,032,000	\$1,382,000
Overall Match Ratio:				74.67%

Project Type

Check all that apply.

- | | |
|---|--|
| <input checked="" type="checkbox"/> Bike/Pedestrian facilities | <input type="checkbox"/> Vegetation management practices |
| <input checked="" type="checkbox"/> Safe routes for non-drivers | <input type="checkbox"/> Archaeological activities |
| <input type="checkbox"/> Abandoned railroad corridors for trails | <input type="checkbox"/> Environmental mitigation activity |
| <input type="checkbox"/> Turnouts, overlooks, and viewing areas | <input type="checkbox"/> Recreational Trails Program |
| <input type="checkbox"/> Control of outdoor advertising | <input type="checkbox"/> Safe Routes to School Program |
| <input type="checkbox"/> Historic preservation of transportation facilities | |

Project Information

1. Project Description:

The North Garrison Road Sidewalk Infill Project (Project) will add sidewalks and buffered bike lanes to the east side of N Garrison Rd between Mill Plain Blvd and NE 12th St. Currently, those traveling on foot, by bicycle or mobility device must use the roadway shoulder. The project will also install an enhanced pedestrian crossing along the corridor at NE 9th St. The Project will close an existing gap in the sidewalk network and enhance safety of the existing bike route in the project area.

Project Information

2. Describe how the project will improve the public travel experience, and travel options, including the benefit to the community:

The Project will create safe and accessible spaces for pedestrians, bicyclists, and small mobility users, separate from vehicle travel by constructing sidewalks and bike lanes along N Garrison Rd between Mill Plain Blvd and NE 12th Street. These safety improvements will enable pedestrians, cyclists, and other small mobility users to travel more comfortably and safely to and from David Douglas Park and other nearby community amenities and retail spaces using active transportation modes. The current configuration creates uncomfortable conditions for all roadway users who share the limited roadway space.

3. Describe how the project provides a connection between modes, or improves transportation choices, or connects to land use services such as job locations, a civic center, library, grocery market, playground, retail center, medical office, school, and other. (Include modes and list of specific land uses connect within 1/2 mile of project):

The Project will provide separate roadway space and a safe connection for vulnerable road users to access David Douglas Park. The Project will create a new active transportation connection to David Douglas Park, The Kamlu Retirement Community, Vancouver Specialty and Rehabilitative Care, several places of worship, multiple multi-family housing complexes and the shopping plazas along Mill Plain Blvd adjacent to the Project area. Garrison Rd provides a necessary north/south connection between the Northwood and North Garrison Heights neighborhoods as well as to the Burnt Bridge Creek Trail system via NE 9th Street to NE 87th Ave. The Project will also increase safety for residents traveling along Garrison Rd to access the new C-TRAN Bus Rapid Transit service being implemented on the Mill Plain Blvd corridor.

Project Information

4. Describe how the project relates to an adopted plan such as the GMA plan, modal plan, neighborhood plan or other planning process. (Include name of Plan and attach a copy of page from plan that including project by name):

The 2004 City of Vancouver Transportation System Plan identifies the need for sidewalk and bicycle improvements throughout the community. Plan to increase in safe and efficient pedestrian and bicycle facilities with equal access to the transportation system. (p.24) N Garrison Rd is identified in the Pedestrian and Bicycle Network maps as a location for proposed pedestrian improvements and bike routes. (p. 25, 29)

The 2017 City of Vancouver Sidewalk Infill Prioritization Memo references the Garrison Sidewalk project and network connectivity to prioritizing need for sidewalk infill projects. (p. 3,5,7,9-13)

The 2019 City of Vancouver Sidewalk Management Program Report lists the Garrison Sidewalk Project on the Grants Prioritization Map as a priority project area. (p 11-14)

The Draft 2024 City of Vancouver Transportation System Plan establishes Complete Corridors policy (p 5), Critical Network Gaps to address network gaps for walking, including access to bus stops, and small mobility use (p 6), and a Low Stress Mobility Network, including lower-stress facilities such as neighborhood greenways and shared-use paths, that prioritizes safety and comfort for all people and ages. (p 12-13)

5. Describe to what extent the project will improve mobility for disadvantage populations, including elderly, disabled minority, and low income populations:

A Composite Equity Score was calculated for the Project area for the 2017 City of Vancouver Sidewalk Infill Prioritization Memo. The three census blocks that encompass the project area score Medium to High equity needs compared to the average census block group in the city of Vancouver. The inputs that contribute to the composite score include:

- The population percentage that identifies as people of color: between 3% and 65%
- People under the age of 18 or over the age of 65: between 29% and 42%
- Median household income: between \$19,952 and \$65,132
- Lack of access to a vehicle: between 2% and 23%.

The Project will create separated facilities for pedestrians and small mobility users with ADA accessible curb cuts and ramps make getting around easier for all road users, including community members experiencing a disability.

6. List affordable house complex and number of housing units that are within 1/2 mile of project:

The following list the building name | address | number of affordable units:

Highlands Apartments | 7625 Delaware | 147 units
Belair | 108 N Garrison | 36 units
Hill Villa | 801 N Garrison | 64 units
Inland Empire | 911 N Garrison | 8 units
Inland Empire | 1301 N Garrison | 2 units
Parkview Apartments | 7806 NE 12th | 104 units

TOTAL: 7 buildings, 361 units

Project Information

7. Identify the safety issues addressed by project (collision data, lack of adequate safe crossing or access, lack of separated facility, high speed or volume, other):

In the last 5 years (2022-2018), there have been 9 collisions on or adjacent to the Project area, two of which involved pedestrians. Only one crossing exists in the project area on the north side of the intersection at N Garrison Rd and Mill Plain Blvd. Currently, there are no crossings or continuous sidewalks to the David Douglas Park on either side of N Garrison Rd. Separated pedestrian facilities and a marked crossing will make access community amenities like David Douglas Park easier for vulnerable road users, and enhanced bike lanes will improve the connectivity of the bike network in this area.

8. Describe how the project addresses the safety issues identified:

There are not separated bike and small mobility facilities on N Garrison Rd as this is currently a shared roadway but would greatly enhance the user comfort and safety as this is a key connecting route on N Garrison Rd to NE 9th St between Mill Plain Blvd and NE 87th Ave, where there are existing bike lanes.

9. Readiness:

- Design at 70% or higher
- Right of way acquisition complete or not needed
- Environmental permits approved

Please explain:

The Project has solid preliminary designs and will be able to move to finalize designs and move quickly to construction.

Project Information

10. Describe how the local community and other agencies have been involved in the planning process for the project.

List any opposition to the project and how it was overcome:

The Project has received \$700,000 in funding from the Washington State Legislature through their adoption of the 2022 Move Ahead Washington transportation package. This funding came because of a grassroots community effort coupled with support from our local state legislative representatives and the Southwest Washington Regional Transportation Council.

11. Describe how the project improves public health and increase physical activity:

Physical activity is important for people to improve their individual and communal health. This project will help enable community members, with a safer opportunity to utilize a park, mobility lanes, and sidewalks, to engage in more physical activity in their neighborhoods.

This project closes a connectivity gap in the City's sidewalk and bike lane network. Improved access to recreational opportunities at David Douglas Park to engage in physical activity and play in a low-stress environment enables users to access affordable social and exercise opportunities. Improving the safety and connectivity of sidewalk and mobility lane networks supports a more physically active community to contribute to overall mental and physical health and wellbeing. The Project will also provide better access to green space, which has been shown to improve mental health, and also facilitate community connections, increasing social wellbeing too.

12. Describe how the project includes design elements that contribute to quality of life:

David Douglas Park and the nearby Burnt Bridge Creek trail system are community amenities that enrich the quality of life for those living nearby or in the City as well as coming from elsewhere to experience the outdoor amenities Vancouver has to offer. Improving access and connectivity along NE Garrison Rd will support these public amenities and improve equitable access to quality green and community spaces within the City.

Project Information

13. List all funding partners contributing to the project:

Funding Source	Amount
City of Vancouver – Street Fund	\$332,225
State Earmark – 2022 Move Ahead Washington	\$700,000

Other Information

You may use this space to provide any additional project information considered worth noting:





Image 1: A cyclist is riding south on N Garrison Road with David Douglas Park to the west. The east side of the road has no sidewalks, where cars are parked along the road. A pedestrian is walking south on a partial sidewalk. The Project will add sidewalk on the east side of the road where cars are currently parked and an enhanced pedestrian crossing to connect the sidewalk at NE 9th St.



Image 2: A cyclist is riding south next to the curb on N Garrison Road. David Douglas Park is visible behind them. A car travels north on the east side of the road. The road has a yellow dividing line and no bike lane is marked. The Project will add a designated bike lane.



March 1, 2023

Dale Robins
SW Washington Regional Transportation Council
1300 Franklin St Ste 185
Vancouver, WA 98660

RE: North Garrison Road Sidewalk Infill Project – Transportation Alternatives Program
2023

Dear Mr. Robins:

C-TRAN offers our support for the City of Vancouver's North Garrison Road Sidewalk Infill Project to be awarded a Transportation Alternatives Program (TAP) grant to improve active transportation options and transit accessibility.

The Project will close an existing sidewalk gap and creates new mobility/bike lanes along Garrison Road between Mill Plain Boulevard and NE 12th Street. This Project will provide a new critical connection for people walking, biking, rolling, and accessing transit in the adjacent neighborhoods of North Garrison Heights, Vancouver Heights, and Northwood. The Project will create safer access to David Douglas Park and commercial areas at the southeast end of the corridor. The Project will also improve access to C-TRAN's Bus Rapid Transit service currently being implemented on Mill Plain Boulevard, with stops at the Garrison Road intersection.

The Project will:

- Install a new enhanced pedestrian crossing at NE 12th Street to David Douglas Park;
- Improve the existing bike network on Garrison Road and enhance the connection to the Burnt Bridge Creek Trail on NE 87th Avenue; and
- Increase the active transportation network that contributes to improved mental and physical health and wellbeing.

We recommend this project for a TAP grant award to support this important active transportation infill project.

Sincerely,

A handwritten signature in blue ink, appearing to read "Shawn M. Donaghy".

Shawn M. Donaghy
Chief Executive Officer

« OUR COMMUNITY, OUR PROMISE »

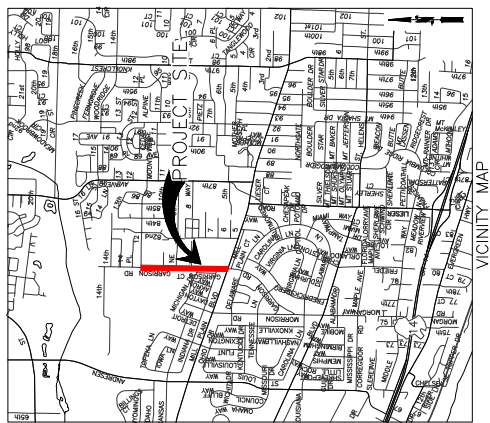
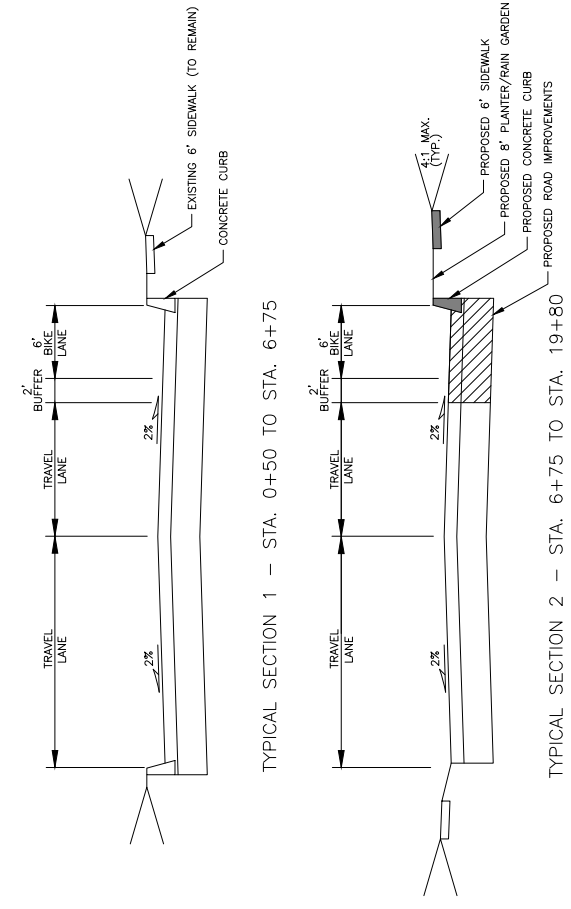
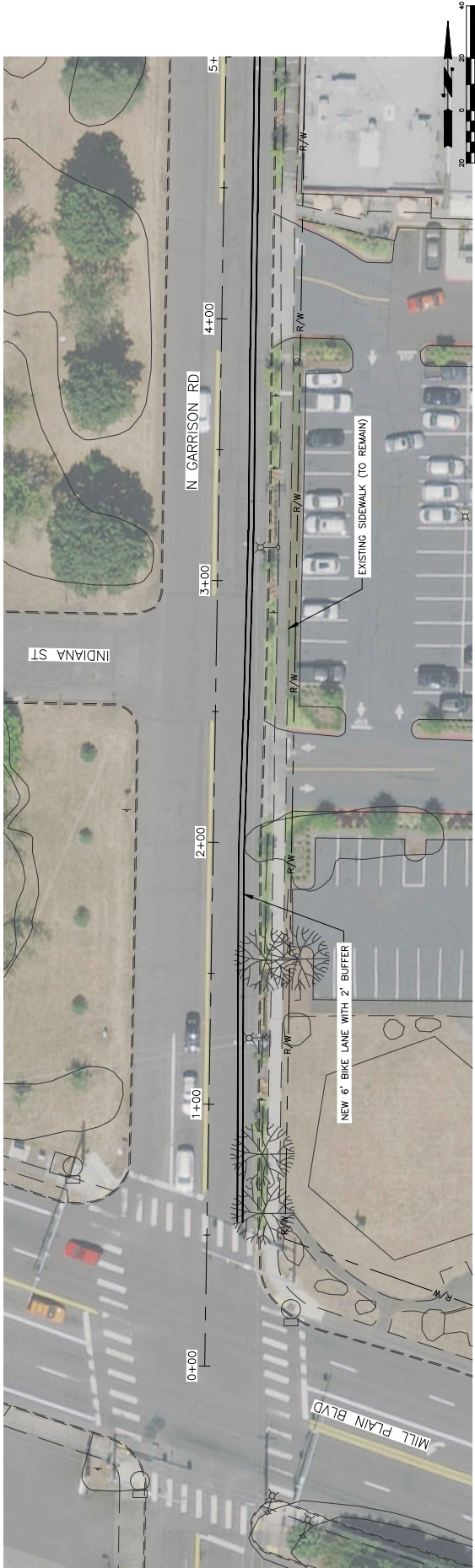

LEGEND:

	ROAD IMPROVEMENTS
	SIDEWALK
	RIGHT OF WAY ACQUISITION
	TEMPORARY CONSTRUCTION EASEMENT
	R/W - EXISTING RIGHT OF WAY LINE
	R/W - PROPOSED RIGHT OF WAY LINE



GARRISON RD SIDEWALK INFILL
FROM MILL PLAIN BLVD TO NE 12TH ST
SHEET 1 OF 3

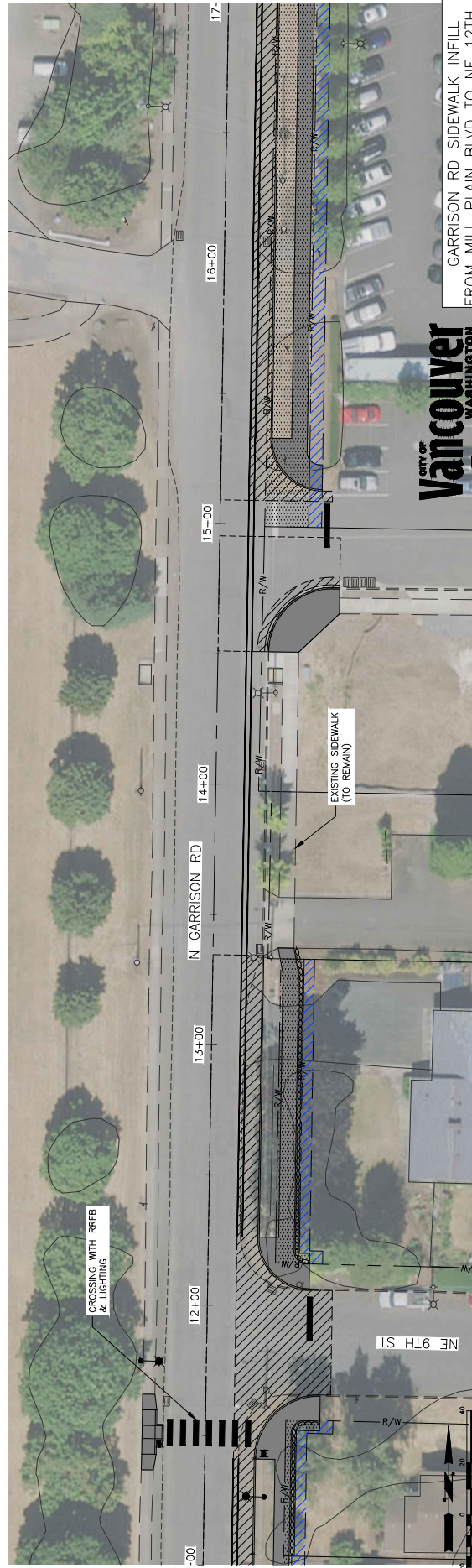
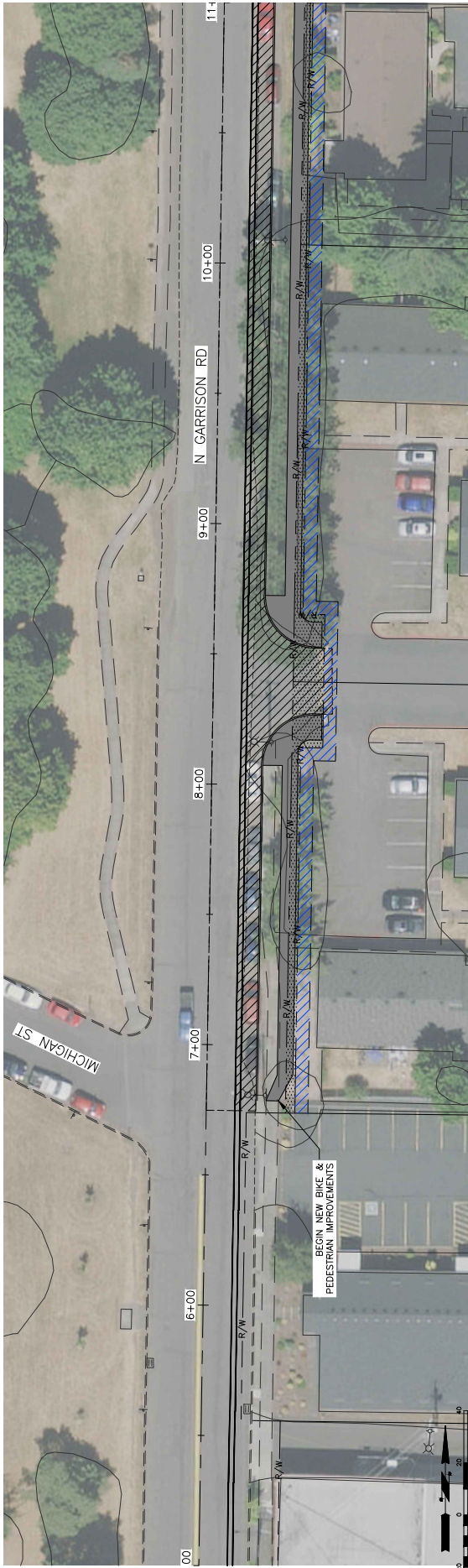

GARRISON RD SIDEWALK INFILL
 FROM MILL PLAIN BLVD TO NE 12TH ST
 SHEET 2 OF 3

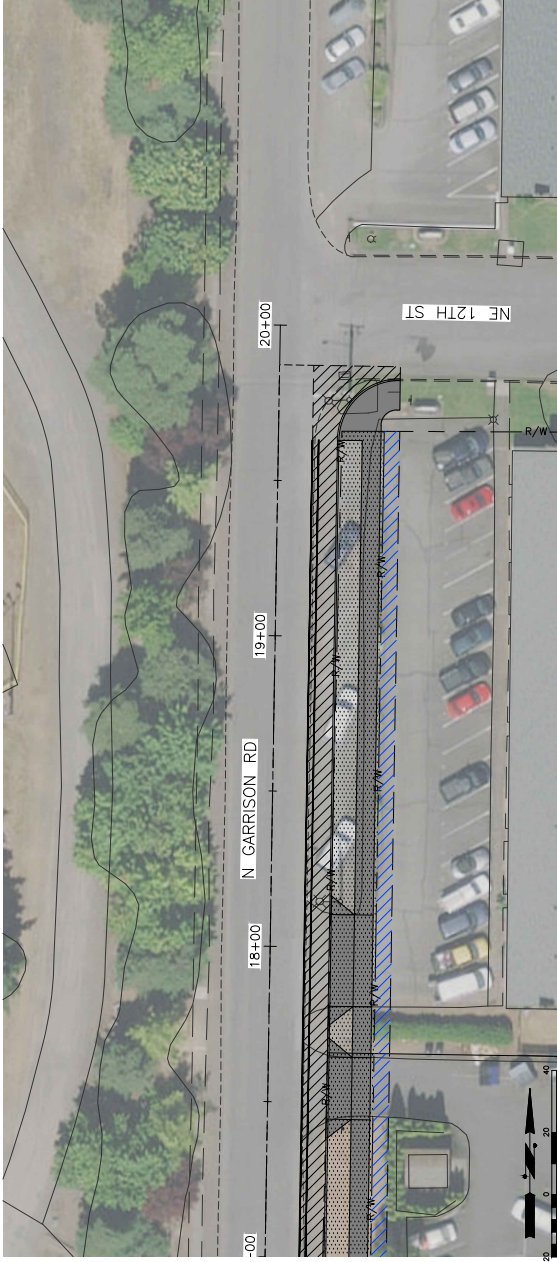

GARRISON RD SIDEWALK INFILL
 FROM MILL PLAIN BLVD TO NE 12TH ST
 SHEET 3 OF 3